

DOOSAN

Construction Equipment

DX340LCA

Engine Power	SAE J1349, net 185 kW (247 HP) @ 1,800 rpm
Operational Weight	34,400 kg (75,839 lb)
Bucket Capacity (SAE/PCSA)	1.25 ~ 2.32 m ³ (1.63 ~ 3.03 yd ³)





**DOOSAN DX340LCA HYDRAULIC EXCAVATOR :
PROVIDING OPTIMUM VALUE
TO THE END USER**

DX340LCA

A NEW MODEL DOOSAN DX340LCA HYDRAULIC EXCAVATOR :

- Improved ergonomics, increases comfort and excellent all round visibility ensuring a safe and pleasant working environment.
- Improved reliability is achieved through the use of high performance materials combined with new methods of structural stress analysis, and leads to increased component life



7 INCH MONITOR

- New, user-friendly LCD color monitor with full access to machine settings and maintenance data.
- Operator can see rear view through new monitor (If customer selects rear view camera option)



TROPICAL HYDRAULIC OIL (ISO VG 68)

- Maintain best performance of your machine by keeping optimum viscosity in tropical area.

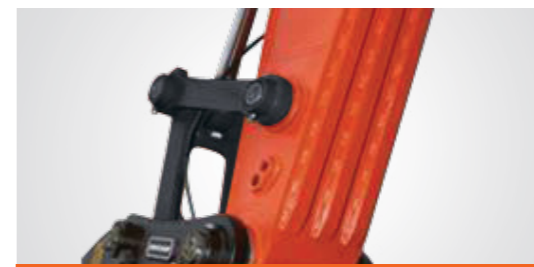

HEAVY-DUTY FRONT

- Overall reinforcement of steel plate by increasing thickness. (Side plate 20%, Bottom 15%)
- Reinforced boom-end bracket and enlarged arm-center boss
- Enlarged arm-end boss and reinforcement plate with abrasion-resistant beams.



ADVANCED HD CABIN (OPTIONAL)

- ROPS, FOPS optional
- The latest interior (MP3, Joystick, Air suspension seat, etc.)



ADVANCED FRONT BUSH

- EM bushing (Enhanced Macro-surface)
- Pocket & Dimple surface pattern : Optimized greasing & Trap foreign object
- Wear resistant solid lubricant coating : Noise free & enhanced anti-seizure property
- 30% longer life time than competitors



ADVANCED H-CLASS BUCKET

- Doosan new H-class bucket has the best strength of steel & the optimized design
- Add side cutter / add chamfer and inner plate at member part
- Increase bucket solidity and change casting type



PRE CLEANER

- Install rotor type pre-cleaner (Donaldson Top Spin 5"). So filtering efficiency 20% increased



WATER SEPARATOR

- Fuel water separator filters water in fuel and enhance engine's durability and reduce quality problem caused by water in fuel (Extra Filter + Pre Filter + Main Filter)



ADVANCED UNDERCARRIAGE

- Strengthen Sprocket structure and tooth
- Structure to prevent debris



PERFORMANCE & PRODUCTIVITY

DX340LCA

DX340LCA is designed for tough and heavy work environments where need massive force. The performance of the DX340LCA has a direct effect on its productivity.



DOOSAN ENGINE(DE12TIS)

Doosan product gives high performance through in-house engine

Doosan engine(In-house) perfectly harmonized with the hydraulic system and provides strong power. Mechanical engine provides high resistance to moisture, dust, and bad fuel quality. The best engine power in the industry(148HP) provides stable working speed even in the heavy workload situation.

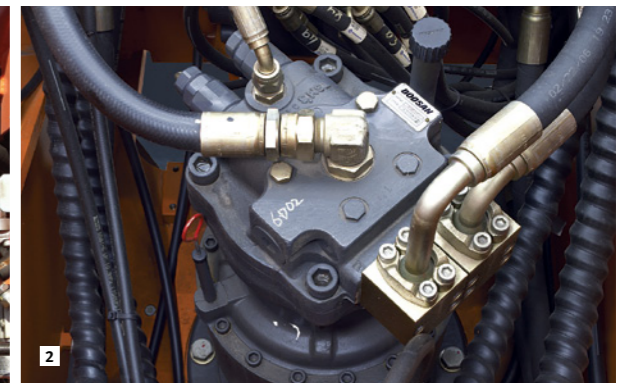
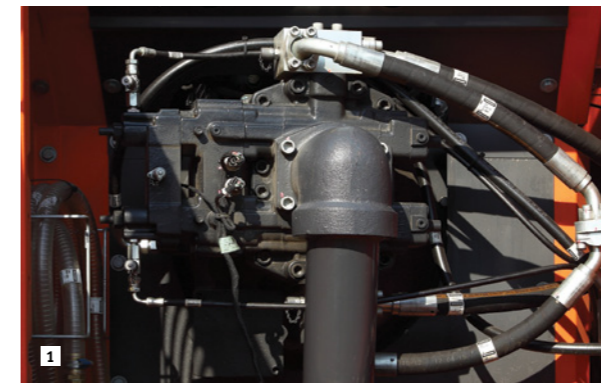
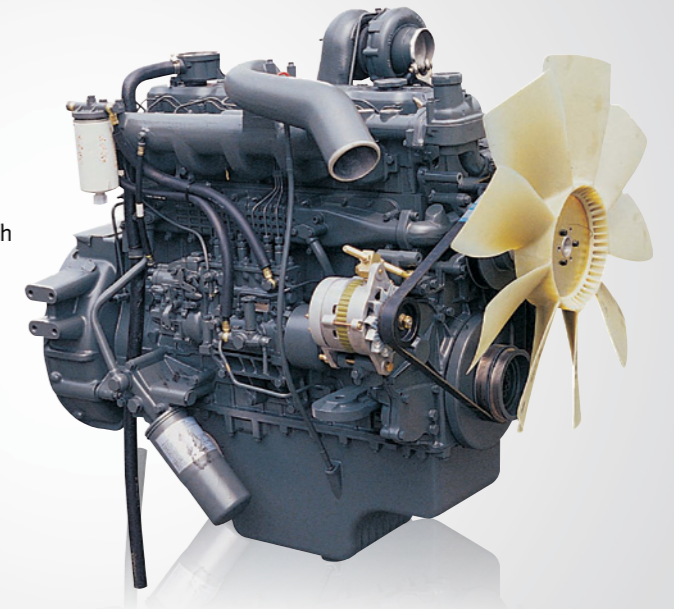

1 HYDRAULIC PUMP

The Main pump has a capacity of 2 x 274 l/min reducing cycle time while a high capacity gear pump improves pilot line efficiency.

2 SWING DRIVE

Shocks during rotation are minimized, while increased torque is available to ensure rapid cycles.

EXCAVATOR CONTROL

Improved Excavator control by New EPOS™ system
The brains of the hydraulic excavator, the EPOS™ (Electronic Power Optimizing system), have been improved, through a CAN (Controller Area Network) communication link, these units are now perfectly synchronised.



DURABILITY & RELIABILITY

DX340LCA

The reliability of an item of plant contributes to its overall lifetime operating costs. DOOSAN uses computer-assisted design techniques, highly durable materials and structures then test these under extreme conditions.



HEAVY DUTY BOOM & ARM BOOM (STANDARD)

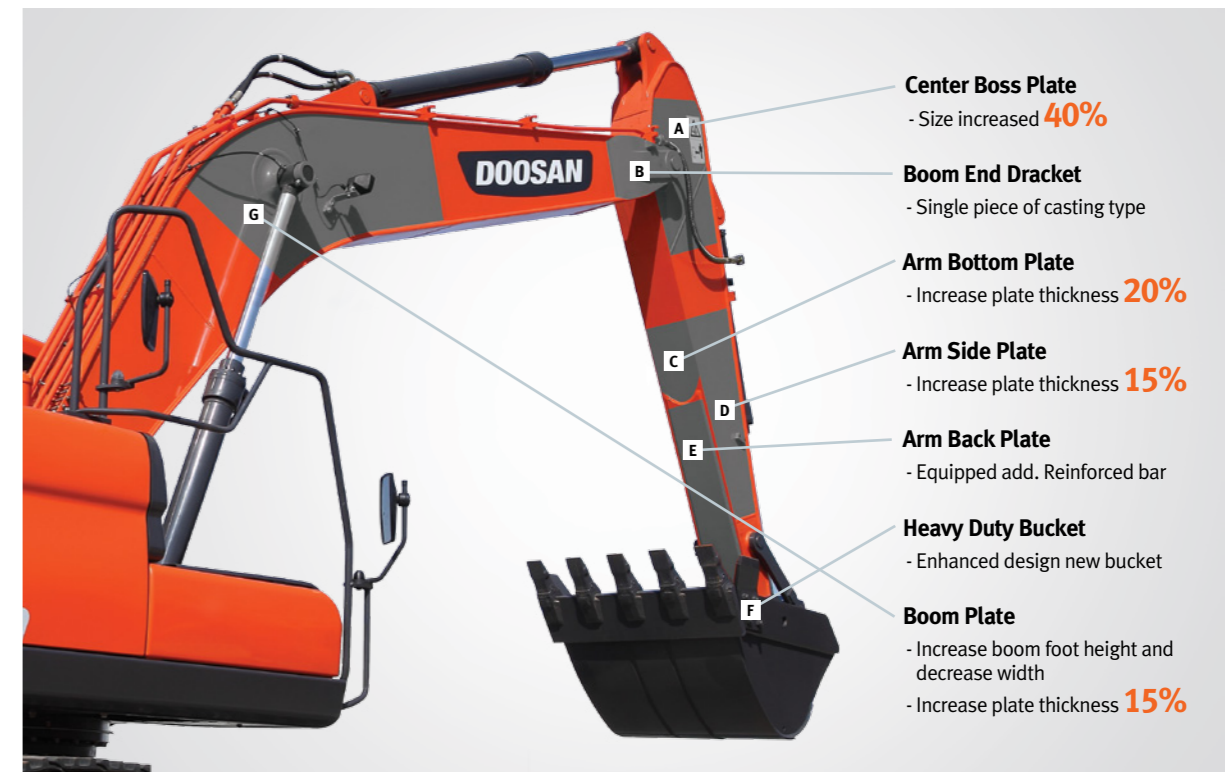

1 ADVANCED PIN-BUSH AND DISK / SHIM TECHNOLOGY

Pocket & Dimple surface pattern : Optimized greasing & Trap foreign object

- Wear resistant solid lubricant coating :
- Noise free & enhanced anti-seizure property.
- Ultra-hard wear-resistant disc :
- Increase the wear resistance and the service intervals.

2 IMPROVED TRACK SPRING AND IDLER

The track spring and the idler have been joined directly to achieve high durability and improved maintenance convenience.

3 TRACKS

The chain is composed of self-lubricating sealed links isolated from all external contamination. The tracks are locked by mechanically bolted pins.



RELIEF CUTOFF

The pump continues to supply flow even when the maximum pressure on the system is reached due to severe working environments and large workloads. Relief cutoff technology of DX340LCA prevents transfer of unnecessary flow to maintain powerful working level at the maximum value while reducing consumption of fuel.



OPTIMIZED LEVER CONTROL & AUTO IDLE

When operator takes a break and leaves the control joystick fixed, both of the engine and the pump are kept in standby mode and prevents unnecessary fuel consumption.



PUMP MATCHING TECHNOLOGY

Engine & pump matching, the new technology of Doosan, fully resolves problems; low responses time of the system, unnecessary fuel consumption. Matching response time between pump and engine efficiently reduces unnecessary fuel consumption as well as exhaust fumes.

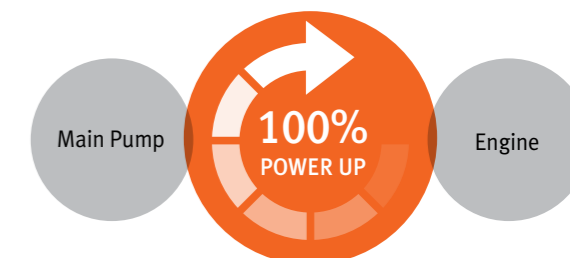
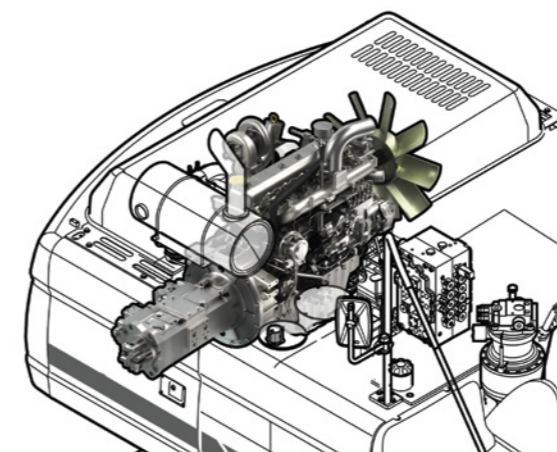



OPERATOR COMFORT

DX340LCA

The work rate of the hydraulic excavator is directly linked to the performance of its operator. DOOSAN designed the DX340LCA by putting the operator at the center of the development goals. The result is significant ergonomic value that improves the efficiency and safety of the operator.



MONITOR



3 power modes for maximum efficiency

- Power mode
- Standand mode
- Economy mode

1 Control panel

2 Navigation modes

- Rearview camera, Display selector

3 Working modes

- Auto-idle & Flow rate control

3 work modes to suit your application

- 1-way mode
- 2-way mode
- Digging mode

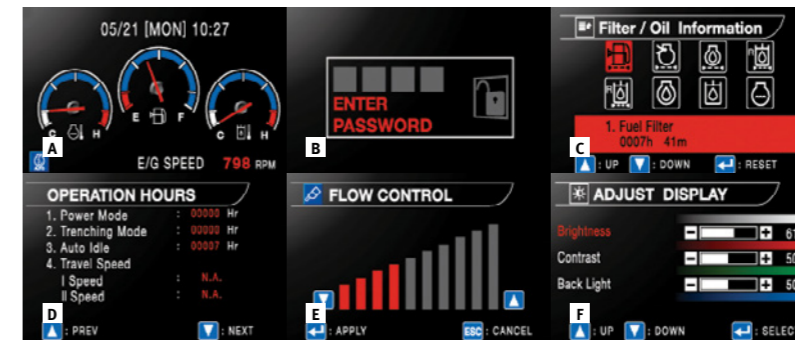

CONTROL PANEL

A Standard screen

B Anti-theft protection

C Filter/oil information

D Operation history

E Flow rate control

F Contrast control



1 CONTROL LEVER

Very precise control of the equipment increases versatility, safety and facilitates tricky operations requiring great precision. Levelling operations and the movement of lifted loads in particular are made easier and safer. DOOSAN designed the DX340LCA by putting the operator at the center of the development goals. The result is significant ergonomic value that improves the efficiency and safety of the operator. More space, better visibility, air conditioning, a very comfortable seat... These are all elements that ensure that the operator can work for hours and hours in excellent conditions.



2 AIR SUSPENSION SEAT (OPTIONAL)

Equipped with various functions of adjustment forth and back and, and lumbar support, it reduces the vibration of equipment transmitted during work in an effective way. Also for considering winter working environment, Seat warmer functions equipped.



3 REAR CAMERA (OPTIONAL)



EASY MAINTENANCE

DX340LCA

Short maintenance operations at long intervals increase the availability of the equipment on site. DOOSAN has developed the DX340LCA with a view to high profitability for the user.

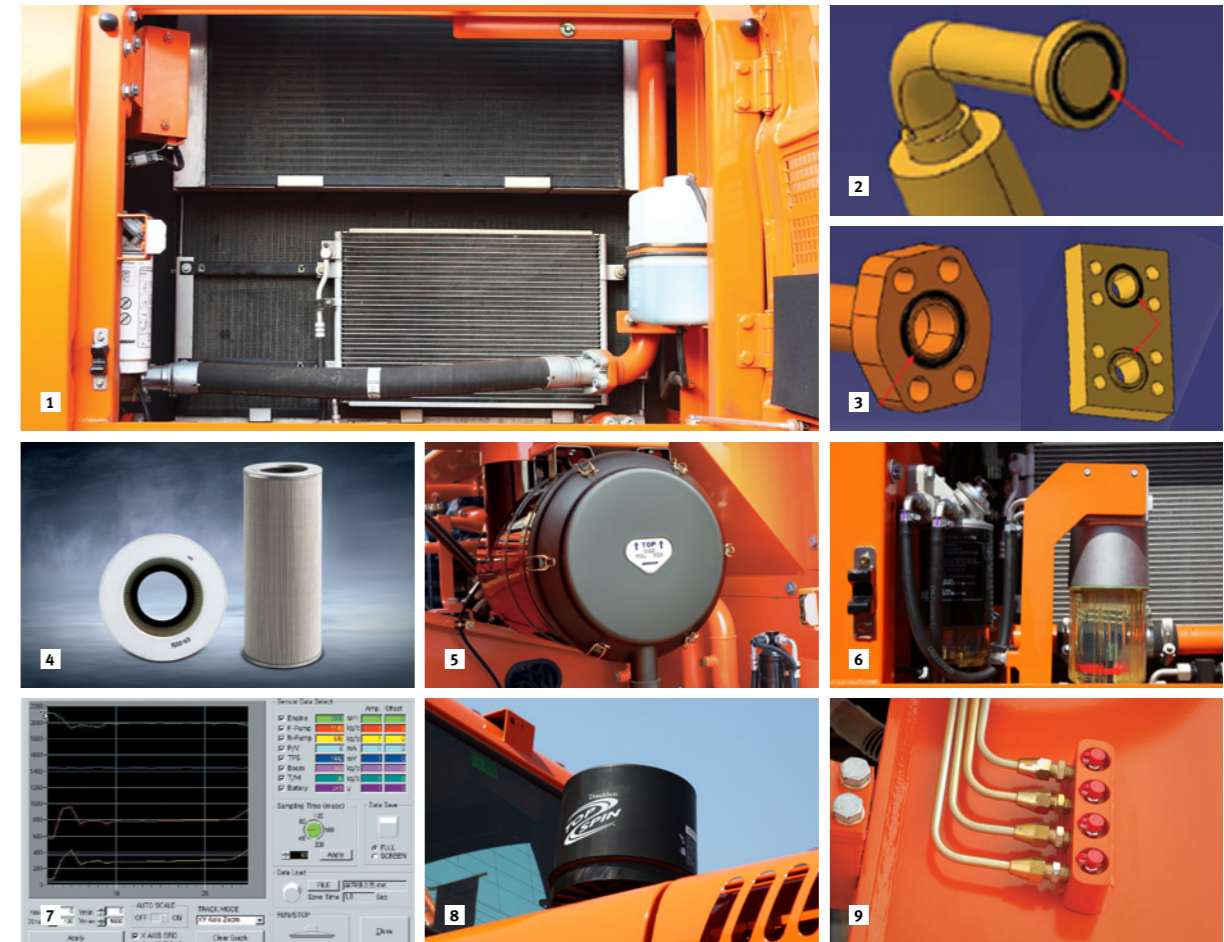

1 EASY MAINTENANCE

Access to the various radiators is very easy, making cleaning easier. Access to the various parts of the engine is from the top and via side panels.

2 IMPROVE THE PILOT HOSE MATERIAL

· Hose material was changed resins to rubber (Resins → Rubber)

3 APPLY IFS(IMPROVED FLANGE SEAL) TYPE

· Captive O-Ring Groove
· Narrow groove hold O-ring in more effective way.
· This will prevent leaking by O-Ring damage.

4 HYDRAULIC OIL RETURN FILTER

The protection of the hydraulic system is made more effective by the use of glass fiber filter technology in the main oil return filter. This means that with more than 99.5% of foreign particles filtered out, the oil change interval is increased.

5 AIR CLEANER

The large capacity forced air cleaner removes over 99% of airborne particles, reducing the risk of engine contamination and making the cleaning and cartridge change intervals greater.

6 WATER SEPARATOR

High efficiency fuel filtration is attained by the use of multiple filters, including a fuel pre-filter fitted with a water separator that removes most moisture from the fuel.

7 PC MONITORING (DMS)

A PC monitoring function enables connection to the EPOS™ system, allowing various parameters to be checked during maintenance, such as pump pressures, engine rotation speed, etc. and these can be stored and printed for subsequent analysis.

8 PRE CLEANER

Install rotor type pre-cleaner (Donaldson Top Spin 5"). So filtering efficiency 20% increased

9 CENTRALIZED GREASE INLETS FOR EASY MAINTENANCE

The boom & arm grease inlets are grouped for easy access.

* Option spec info is included to the images contained in this material and may not be the same with the actual specs.

TELEMATICS SERVICE (OPTIONAL)

GLOBAL PARTS NETWORK

TELECOMMUNICATIONS

Data flow from machine to web



TELEMATICS SERVICE TERMINAL

Telematics Service terminal is installed to machine / connected to EPOS™



TELECOMMUNICATION

GPS, EPOS™ data is sent to designated server by GSM, Satellite telecommunication

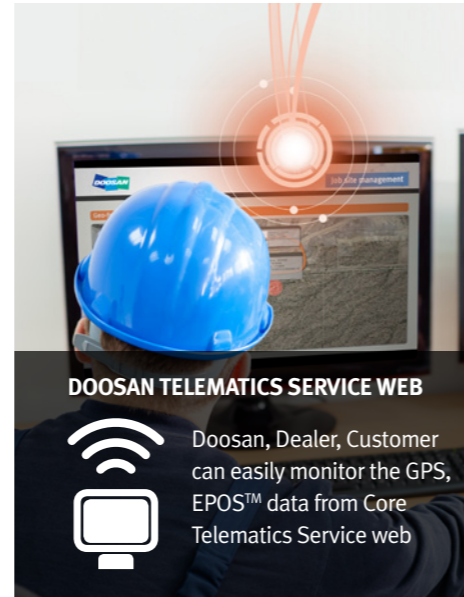

DOOSAN TELEMATICS SERVICE WEB

Doosan, Dealer, Customer can easily monitor the GPS, EPOS™ data from Core Telematics Service web

FUNCTIONS

Doosan Telematics Service provides various functions to support your great performance

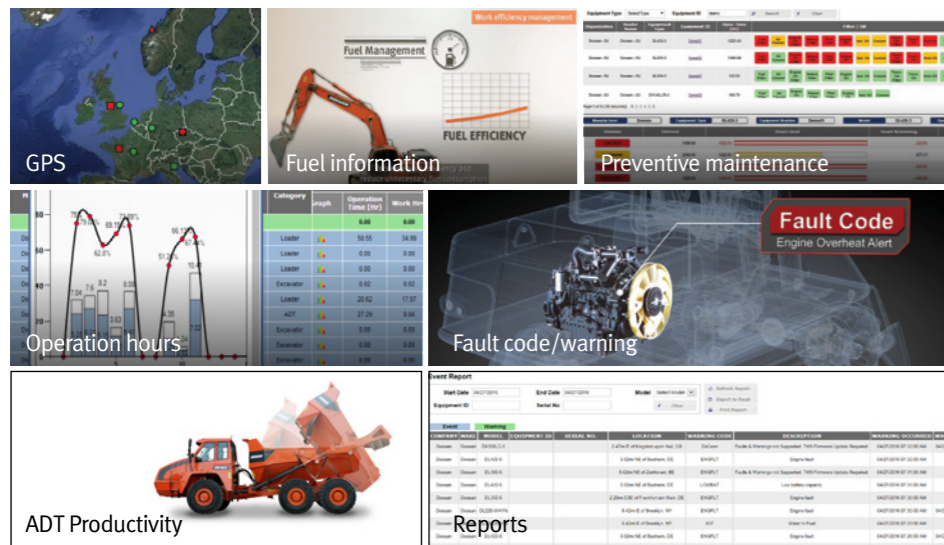

TELEMATICS SERVICE BENEFITS

Doosan and dealer support customers to improve work efficiency with timely and responsive services

Customer

- Improve work efficiency
- Timely and preventive service
- Improve operator's skills by comparing work pattern
- Manage fleet more effectively

Dealer

- Better service for customers
- Provide better quality of service
- Maintain machine value
- Better understanding of market needs

Doosan

- Responsive to customer's voice
- Utilize quality-related field data
- Apply customer's usage profile to developing new machine

GLOBAL PDC (PARTS DISTRIBUTION CENTER) NETWORK

Doosan provides fast and precise worldwide delivery of genuine Doosan parts through its global PDC (parts distribution center) network.

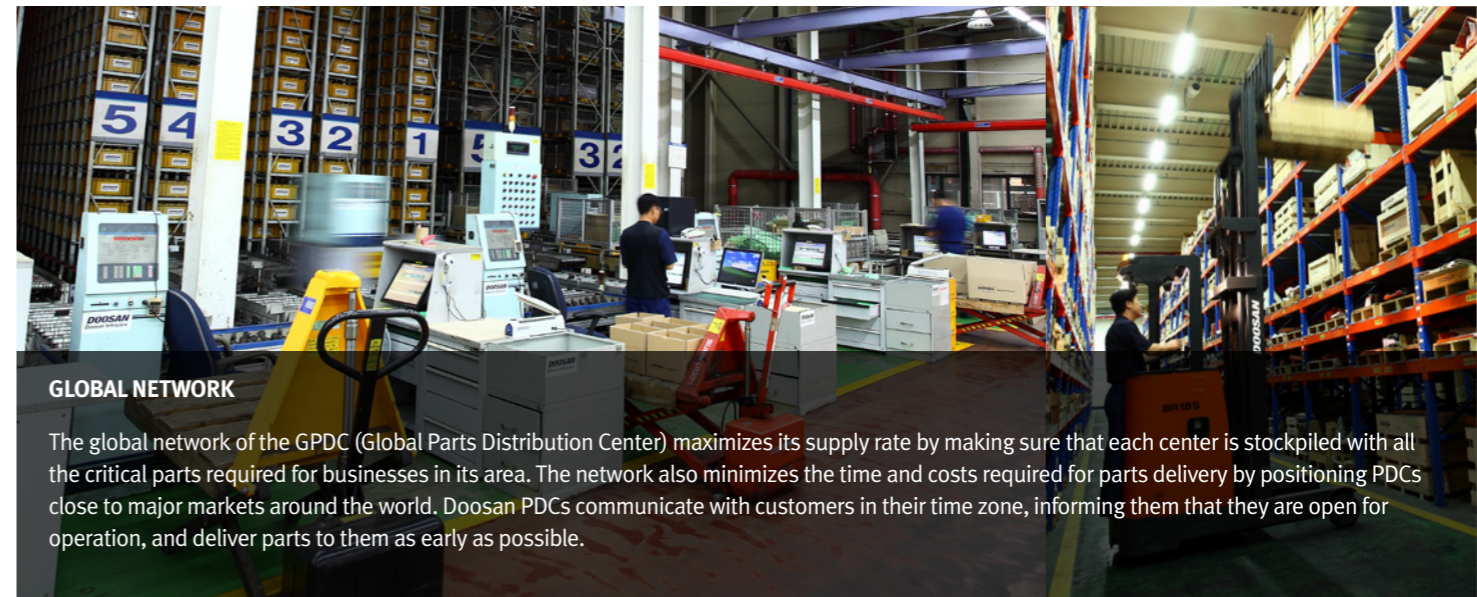

GLOBAL NETWORK

The global network of the GPDC (Global Parts Distribution Center) maximizes its supply rate by making sure that each center is stocked with all the critical parts required for businesses in its area. The network also minimizes the time and costs required for parts delivery by positioning PDCs close to major markets around the world. Doosan PDCs communicate with customers in their time zone, informing them that they are open for operation, and deliver parts to them as early as possible.

The Global Parts Distribution Center Network

PDCs had been set up as shown below, including Mother PDC in Ansan, Korea. The seven other PDCs include one in China (Yantai), one in the USA (Chicago), one in Brazil (Campinas), two in Europe (Germany and the UK), one in the Middle East (Dubai), and one in Asia (Singapore).



MPDC : Mother Parts Distribution Center PDC : Parts Distribution Center

FUNCTION	EXCAVATOR	WHEEL LOADER	ADT
GPS	All models	All models	All models
E-mail reports	All models	All models	All models
Operation hours	All models	All models	All models
Maintenance parts	All models	Tier 4 only	All models
Fault code/ Warning	All models	Tier 4 only	All models
Fuel information	All models	Tier 4 only	All models
Dump capacity	N/A	N/A	All models

PDC BENEFIT

- Distribution Cost Reduction
- Maximum Parts supply rate
- Shortest distance/time parts delivery
- Real-time service support
- Minimum downtime

Heavy Construction Bucket, which is also called Heavy Duty bucket, is the most commonly used bucket in the construction equipment market and is designed mainly for use in heavy construction but also used in low density mining and quarry application.



General Purpose bucket

which is also called General Purpose bucket, is designed for digging and re-handling soft to medium materials e.g. materials with low wear characteristics such as top-soil, loam, coal.



Heavy Duty bucket

which is also called Heavy Duty bucket, is the most commonly used bucket in the construction equipment market and is designed mainly for use in heavy construction but also used in low density mining and quarry application.



Severe Duty bucket

which is also called Severe Duty bucket. The bucket is designed for use in high density mining and quarry application using high strength and high abrasion resistance materials. It can be used in the toughest of applications.



Extra Severe Duty Bucket

which is also called X class bucket. The bucket is designed for use in high density mining and quarry application using high strength and high abrasion resistance materials. It can be used in the toughest of applications.



BUCKET



	Capacity (SAE/PCSA)	Capacity (SAE/PCSA)
GENERAL PURPOSE BUCKET	1.25 / 1.49 / 1.61 / 1.83 m ³	SEVERE DUTY BUCKET 1.56 / 1.71 / 1.92 / 2.22 m ³
HEAVY DUTY BUCKET	1.44 / 1.66 / 1.81 / 2.03 / 2.32 m ³	ROCK BUCKET 1.28 m ³

DEMOLITION



	Model	Weight	Tool diameter	Frequency
HYDRAULIC BREAKER	DXB230H	2,465 kg	150 mm	310~680 BPM
	Model	Weight	Max. Jaw opening	Force at Tip
FIXED PULVERIZER	FP34	2,745 kg	1,061 mm	78 t
ROTATING CRUSHER	RC34	2,950 kg	1,056 mm	78 t
MULTI-PROCESSOR	C / D / P / S MP34	3,030 / 3,000 / 3,130 / 2,990 kg	1,119 / 983 / 1,008 / 573 mm	95 / 101 / 103 / 104 t
STEEL SHEAR	SS34	3,591 kg	576 kg	460 t

C : Crushing jaw
D : Demolition jaw
P : Pulverizing jaw
S : Shearing jaw

MATERIAL HANDLING



	Model	Weight	Max Jaw opening	Max. Closing Force	Capacity
MULTI-GRAPPLE	MG34	2,275 kg	2,350 mm	9.2 t	1.10 m ³
STONE GRAPPLE	SG34	1,700 kg	2,300 mm	-	0.62 m ²
WOOD GRAPPLE	L / P WG34	1,595 / 1,455 kg	2,300 mm	-	0.75 m ²
LOG GRAPPLE	L / P LG34	1,815 / 1,780 kg	2,300 mm	-	0.88 m ²
ORANGE GRAPPLE	OG34	2,000 kg	2,615 mm	-	0.72 m ²

L : Link type
P : Pendulum type

EARTH MOVING



	Model	Weight	Max. Jaw opening	Capacity
CLAMSHELL BUCKET	CB34	2,040 kg	1,985 mm	1.50 m ³
	Model	Weight	Base plate (WxL)	Impulse force
PLATE COMPACTOR	PC34	1,807 kg	1,000 x 1,300 mm	17.3 t
	Model	Weight	Length	
RIPPER	RP34	740 kg	1,620 mm	

CONNECTING



	Model	Weight	Bucket Pin dia.	Working rage (Pin to Pin)
Quick Coupler	QC34	629 kg	100 mm	539 ~ 606 mm

TECHNICAL SPECIFICATIONS

ENGINE

Model	Doosan DE12TIS
Type	4-Cycle ATA Intercooler in-Line
Number of cylinders	6
RATED HORSE POWER	195 kW (262 HP) @ 1,800 rpm (SAE J 1995,Gross) 184 kW (247 HP) @ 1,800 rpm (SAE J1349)
Max torque	114 kgf.m @ 1,400 rpm
Piston displacement	11,051cc
Bore & stroke	∅123mm x 155 mm
STARTING MOTOR	24 V x 6.0 kW
batteries	12 V x 2/150 AH
Air cleaner	Double element

HYDRAULIC CYLINDERS

The piston rods and cylinder bodies are made of high-strength steel. A shock absorbing mechanism is fitted in all cylinders to ensure shock-free operation and extend piston life.

Cylinders	Quantity	Bore x Rod diameter x stroke
Boom	2	150 X 100 X 1,430mm
Arm	1	170 X 120 X 1,805mm
Bucket	1	150 X 100 X 1,300mm

WEIGHT

Triple grouser

Shoe width	Operating weight	Ground pressure (kgf/cm ²)
(STD)600G mm	0.66 kgf/cm ²	34.4 ton
(OPT)700G mm	0.56 kgf/cm ²	34.5 ton
(OPT)800G mm	0.50 kgf/cm ²	34.8 ton
(OPT)850G mm	0.47 kgf/cm ²	35.0 ton
(OPT)900G mm	0.45 kgf/cm ²	35.2 ton
(OPT)600DG mm	0.67 kgf/cm ²	34.9 ton

HYDRAULIC SYSTEM

The heart of the system is the EPOS™ (Electronic Power Optimizing System). It allows the efficiency of the system to be optimized for all working conditions and minimizes fuel consumption. The new EPOS™ is connected to the engine electronic control via a data transfer link to harmonize the operation of the engine and hydraulics.

- The hydraulic system enables independent or combined operations.
- Two travel speeds offer either increased torque or high speed tracking.
- Cross-sensing pump system for fuel savings.
- Auto deceleration system.
- Two operating modes, two power modes.
- Button control of flow in auxiliary equipment circuits.
- Computer-aided pump power control.

Main pumps

Parallel, Bentaxis, Piston
max flow : 2x274 l/min
Displacement : 157 cc/rev
weight : 180kg

Pilot pump

Gear pump - max flow : 22.5 l/min
Pilot pump : 11.86 cc/rev
Relief valve pressure : 40 kgf/cm²

Main relief Pressure

Boom/Arm/Bucket
Working, Travel - 330 [+10~0] kg/cm²
Pressure up - 350 [+10~0] kg/cm²

SWING MECHANISM

High-torque, axial piston motor with planetary reduction gear bathed in oil. Swing circle is singlerow, shear type ball bearing with induction-hardened internal gear. Internal gear and pinion gear immersed in lubricant.

Swing speed - 0 to 8.9 rpm

MAX. SWING TORQUE - 11660 kgf.m (EFF.=0.863)

UNDERCARRIAGE

Chassis are of very robust construction, all welded structures are designed to limit stresses.High-quality material used for durability. Lateral chassis welded and rigidly attached to the undercarriage. Track rollers lubricated for life, idlers and sprockets fitted with floating seals. Tracks shoes made of induction-hardened alloy with triple grousers. Heat-treated connecting pins.Hydraulic track adjuster with shock-absorbing tension mechanism.

Upper rollers(Standard shoe) - 2

Lower rollers - 9

Track shoes - 48

Overall track length - 4,940mm

DRIVE

Each track is driven by an independent, high-torque, axial piston motor through planetary reduction gear. Two levers or foot pedal control provide smooth travel or counter-rotation upon demand.

Travel speed (HIGH/low) - 3.1/4.7 km/h (EFF.=99.0/95.2%)

Maximum traction force - 27.0 / 15.1 ton (EFF.=75.7/68.8%)

Gradeability - 70%

REFILL CAPACITIES

Fuel tank - 550 l

Cooling system (Radiator capacity) - 34 l

Engine oil - 28 l

Swing drive (=Swing Device = Swing motor + Swing Reduction Gear)

- 6 l

Final drive (=Travel Device = travel motor + travel reduction gear)

- 2x5.5 l

Hydraulic tank (FULL) - 380 l

BUCKET

		TRACK	STD Track						Narrow Track									
		C/W (ton)	7.1						7.1									
		SHOE (mm)	600						600									
Bucket Type	Capacity(m ³)		Width (mm)		Radius (mm)	Weight (kg)	6.5m Boom			6.5m HD		6.2m Boom	6.5m Boom			6.5m HD		6.2m Boom
	SAE/PCSA	CECE	W/O Cutter	With Cutter			2.6m Arm	3.2m Arm	3.95m Arm	2.6m Arm	3.2m HD		2.6m Arm	2.6m Arm	3.2m Arm	3.95m Arm	2.6m Arm	
General Purpose bucket	1.25	1.10	1,668	1,278	1,704	1,249	A	A	A	A	A	A	A	A	A	A	A	A
	1.49	1.30	1,068	1,460	1,704	1,344	A	A	B	A	A	A	A	B	C	A	B	A
	1.61	1.41	1,220	1,550	1,704	1,392	A	A	B	A	A	A	A	B	C	B	B	A
	1.83	1.60	1,372	1,718	1,704	1,522	A	B	B	B	B	A	C	C	D	C	C	B
Heavy Duty Bucket	1.44	1.30	1,460	N/A	1,651	1,309	A	A	A	A	A	A	A	A	B	A	B	A
	1.66	1.49	1,610	N/A	1,651	1,401	A	A	B	A	B	A	B	C	C	B	C	A
	1.81	1.61	1,372	N/A	1,651	1,495	A	B	B	A	B	A	B	C	D	B	C	B
	2.03	1.80	1,460	N/A	1,651	1,587	B	C	C	B	C	B	C	D	X	C	D	C
Severe Duty Bucket	2.32	2.05	1,610	N/A	1,651	1,711	C	D	D	C	D	C	D	X	X	D	X	D
	1.56	1.40	1,668	N/A	1,700	1,865	A	B	B	A	B	A	B	C	D	B	C	B
	1.71	1.53	1,068	N/A	1,700	1,943	B	C	C	B	C	A	C	D	X	C	D	B
	1.92	1.71	1,220	N/A	1,700	2,060	C	D	D	C	D	B	D	D	X	D	X	C
Rock Bucket	2.22	1.96	1,372	N/A	1,700	2,267	D	X	X	D	X	C	X	X	X	X	X	D
	1.28	1.12	1,382	N/A	1,700	1,427	A	A	A	A	A	A	A	A	B	A	A	A
Maximum load pin-on(payload+bucket)							5,411	4,975	4,442	5,396	4,911	5,780	4,817	4,427	3,943	4,801	4,362	5,156

Based on ISO 10567 and SAE J296, arm length without quick change clamp

A : Suitable for materials with density of 2100kg/m³ (3500lb/yd³) or less

B : Suitable for materials with density of 1800kg/m³ (3000lb/yd³) or less

C : Suitable for materials with density of 1500kg/m³ (2500lb/yd³) or less

D : Suitable for materials with density of 1200kg/m³ (2000lb/yd³) or less

X : Not recommended

DIGGING FORCES (ISO)

Arm	Length		Diggingforce (Nom./Press.up, ton)		Bucket	Diggingforce (Nom./Press.up, ton)	
	STD. Arm	3,200mm	[SAE] 16.3 / 17.3 , [ISO] 16.9 / 17.9	G.P		[SAE] 20.4 / 21.7 , [ISO] 23.1 / 24.5	
	Short Arm	2,600mm	[SAE] 20.0 / 21.2 , [ISO] 20.7 / 22.0	H.D		[SAE] 21.5 / 22.8 , [ISO] 23.4 / 24.8	

DIMENSIONS

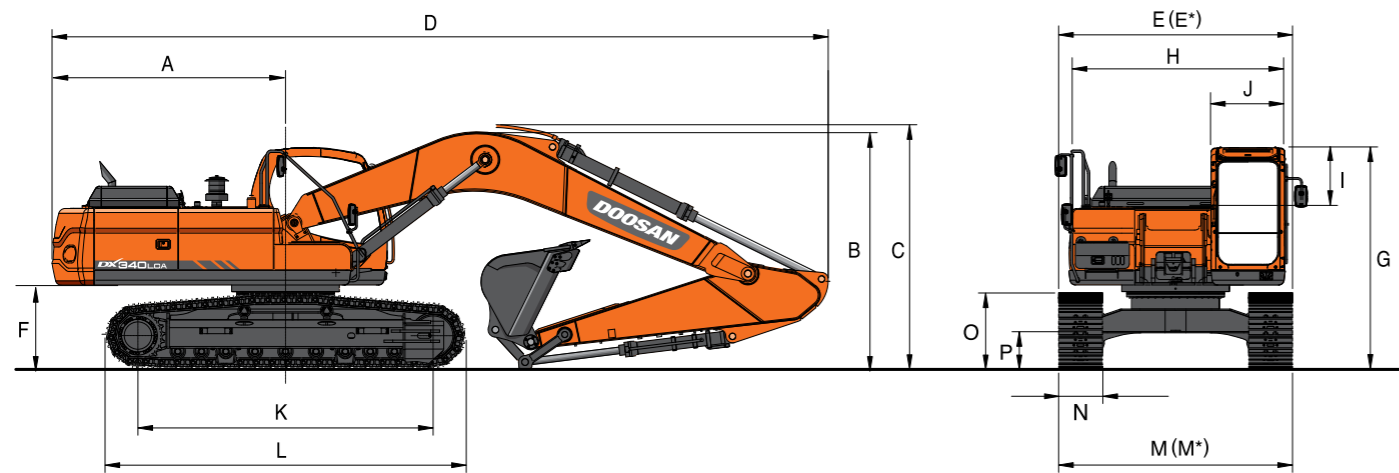

STANDARD

Dimensions (6,500mm(21'4")Boom, 3,200mm(10'6")Arm, 600mm(24")shoe)

Boom Type (One Piece)	(mm)		6,500		6,200
Arm Type	(mm)		3,200	2,600	2,600
Bucket Type (pcsa)	(m ³)		1.49	1.83	2.01
Tail Swing Radius	(mm)	A	3,500	←	←
Shipping Height (Boom)	(mm)	B	3,220	3,475	3,620
Shipping Height (Hose)	(mm)	C	3,360	3,592	3,720
Shipping Length	(mm)	D	11,280	11,380	11,080
Shipping Width (Std.)	(mm)	E	3,280	←	←
Shipping Width (Narrow)	(mm)	E*	3,000	←	←
C/Weight Clearance	(mm)	F	1,195	←	←
Height Over Cab.	(mm)	G	3,125	←	←
House Width	(mm)	H	2,990	←	←
Cab. Height Above House	(mm)	I	845	←	←
Cab. Width	(mm)	J	1,010	←	←
Tumbler Distance	(mm)	K	4,040	←	←
Track Length	(mm)	L	4,940	←	←
Undercarriage Width (Std.)	(mm)	M	3,280	←	←
Shoe Width	(mm)	N	600	←	←
Track Height	(mm)	O	1,048	←	←
Car Body Clearance	(mm)	P	510	←	←

WORKING RANGES

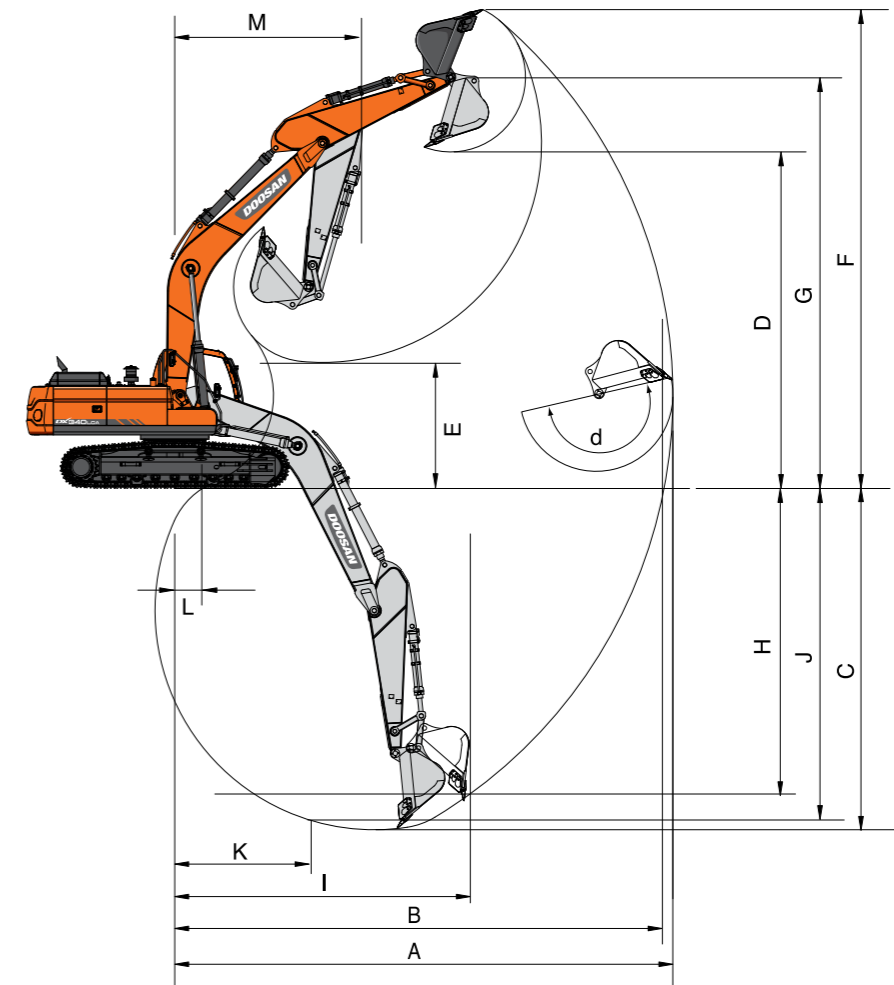

WORKING RANGES

Boom Type (One Piece)	(mm)		6,500		6,200
Arm Type	(mm)		3,200	2,600	2,600
Bucket Type (pcsa)	(m ³)		1.49	1.83	2.01
MAX. digging reach	(mm)	A	11,168	10,586	10,200
Max. digging reach (ground)	(mm)	B	10,975	10,382	9,990
MAX. digging depth	(mm)	C	7,533	6,931	6,635
Max. loading height	(mm)	D	7,196	6,882	6,695
Min. loading height	(mm)	E	2,704	3,355	3,245
Max. bucket pin height	(mm)	F	10,345	9,994	9,510
Max. bucket pin height	(mm)	G	8,898	8,584	8,315
Max. vertical wall depth	(mm)	H	5,916	5,121	2,185
Max. radius vertical	(mm)	I	7,713	7,711	9,265
Max. digging depth 8'line	(mm)	J	7,361	6,719	6,400
Min. radius 8'line	(mm)	K	3,393	3,345	3,085
Min. digging reach	(mm)	L	723	2,180	1,950
Min. swing radius	(mm)	M	4,413	4,438	4,275
Bucket angle	(deg)	d	178	178	178

LIFTING CAPACITY

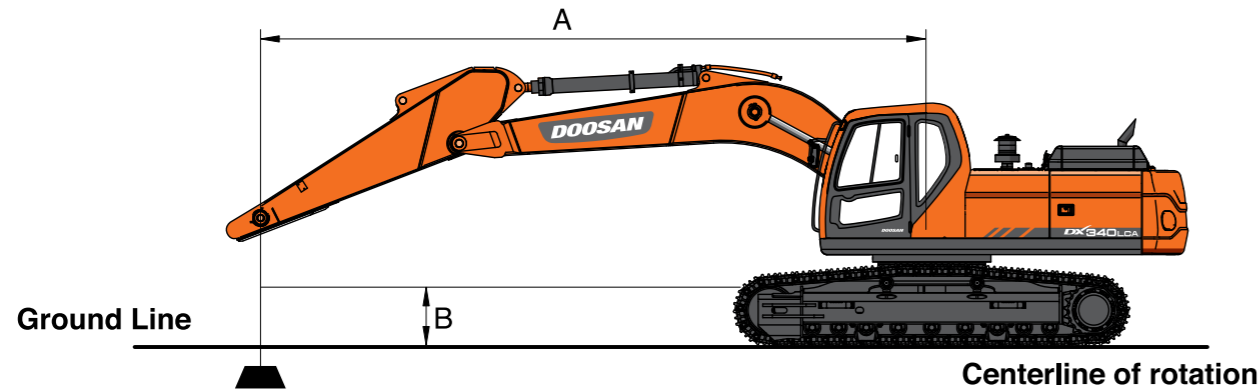

STANDARD

Metric

Boom : 6,500mm(21'4") Arm : 3,200mm(10'6") Bucket : Without Bucket Shoe : 600mm(24") Standard Track : 3,280mm(10'9") Unit : 1,000kg

A(m)	1.5		3.0		4.5		6.0		7.5		9.0		Max. Reach		A(m)	
B(m)	📏	📏	📏	📏	📏	📏	📏	📏	📏	📏	📏	📏	📏	📏	📏	📏
7.5														* 7.68	7.33	7.71
6.0														* 7.78	7.26	8.59
4.5					* 11.99	* 11.99	* 9.58	* 9.58	* 8.33	7.02	* 7.68	5.20		7.58	5.06	9.14
3.0					* 15.08	* 14.22	* 11.03	* 9.33	* 9.07	6.71	7.64	5.07		7.10	4.70	9.42
1.5					* 17.22	* 13.24	* 12.28	* 8.81	* 9.76	6.43	7.49	4.92		6.95	4.57	9.45
0					* 17.80	* 17.80	* 12.95	* 8.48	9.62	6.22	7.38	4.82		7.11	4.65	9.23
-1.5					* 14.10	* 14.10	* 12.76	* 12.91	* 8.35	9.52	6.13			7.64	4.98	8.76
-3.0	* 16.70	* 16.79	* 21.31	* 21.31	* 15.81	* 12.90	* 12.07	* 8.39	* 9.30	6.18				* 8.45	5.72	7.97
-4.5			* 17.23	* 17.23	* 13.14	* 13.10	* 9.96	* 8.63						* 8.35	7.36	6.76

Feet

Unit : 1,000ld

A(ft)	5		10		15		20		25		30		Max. Reach		A(ft)	
B(ft)	📏	📏	📏	📏	📏	📏	📏	📏	📏	📏	📏	📏	📏	📏	📏	📏
25														* 17.04	15.68	25.01
20														* 17.03	15.60	28.04
15					* 25.78	* 25.78	* 20.75	* 20.75	* 18.15	15.11				16.79	11.21	29.92
10					* 32.42	30.70	* 23.86	20.14	* 19.71	14.47	16.44	10.90		15.69	10.39	30.88
5					* 37.17	28.55	* 26.57	19.01	* 21.17	13.86	16.12	10.60		15.33	10.08	31.00
0					* 38.57	27.63	* 28.05	18.29	20.72	13.42	15.90	10.40		15.68	10.26	30.30
-5					* 31.86	* 31.86	* 37.46	27.46	* 27.98	17.99	20.51	13.22		16.88	11.01	28.69
-10	* 37.58	* 37.58	* 46.30	* 46.30	* 34.25	27.75	* 26.07	18.09	19.94	13.35				* 18.63	12.69	26.03
-15			* 37.09	* 37.09	* 28.22	* 28.22	* 21.20	18.64						* 18.36	16.51	21.92

- Lifting Capacities are in Compliance with ISO 10567
- Loading Point is The End of The Arm.
- Capacities Marked with an Asterisk (*) are Limited by Hydraulic Capacities.
- Lifting Capacities Shown Do Not Exceed 75% of Minimum Tipping Loads or 87% of Hydraulic Capacities.
- The Least Stable Position is Over the Side.

📏 : Rating Over Front
📏 : Rating Over Side or 360 Degree

OPTION 1

Metric

Boom : 6,500mm(21'4") Arm : 3,200mm(10'6") Bucket : Without Bucket Shoe : 700mm(28") Standard Track : 3,200mm(10'6") Unit : 1,000kg

A(m)	1.5		3.0		4.5		6.0		7.5		9.0		Max. Reach		A(m)	
B(m)	📏	📏	📏	📏	📏	📏	📏	📏	📏	📏	📏	📏	📏	📏	📏	
7.5														* 7.68	7.38	7.71
6.0														* 7.78	7.31	8.59
4.5					11.99	11.99	* 9.58	* 9.58	* 8.33	7.07	* 7.68	5.24		7.64	5.10	9.14
3.0					15.08	14.32	11.03	9.40	* 9.07	6.76	7.70	5.11		7.16	4.74	9.42
1.5					17.22	13.34	12.28	8.88	* 9.76	6.48	7.55	4.96		7.01	4.61	9.45
0					17.80	12.93	12.95	8.55	9.70	6.27	7.44	4.86		7.17	4.69	9.23
-1.5					14.10	14.10	12.72	12.86	12.91	8.41	9.60	6.18		7.71	5.02	8.76
-3.0	16.79	16.79	21.31	21.31	15.81	13.00	12.07	8.45	* 9.30	6.23				* 8.45	5.77	7.97
-4.5			17.23	17.23	13.14	13.14	* 9.96	8.69						* 8.35	7.42	6.76

Feet

Unit : 1,000ld

A(ft)	5		10		15		20		25		30		Max. Reach		A(ft)	
B(ft)	📏	📏	📏	📏	📏	📏	📏	📏	📏	📏	📏	📏	📏	📏	📏	
25														* 17.04	15.79	25.01
20														* 17.03	15.71	28.04
15					* 25.78	* 25.78	* 20.75	* 20.75	* 18.15	15.22				* 16.87	11.29	29.92
10					* 32.42	30.70	* 23.86	20.14	* 19.71	14.58	16.57	10.98		15.82	10.47	30.88
5					* 37.17	28.55	* 26.57	19.01	* 21.17	13.97	16.25	10.69		15.46	10.17	31.00
0					* 38.57	27.63	* 28.05	18.29	20.90	13.52	16.03	10.49		15.81	10.34	30.30
-5					* 31.86	* 31.86	* 37.46	27.46	* 27.98	17.99	20.68	13.33		17.03	11.10	28.69
-10	* 37.58	* 37.58	* 46.30	* 46.30	* 34.25	27.75	* 26.07	18.09	* 19.94	13.46				* 18.63	12.79	26.03
-15			* 37.09	* 37.09	* 28.22	* 28.22	* 21.20	18.64						* 18.36	16.64	21.92

- Lifting Capacities are in Compliance with ISO 10567
- Loading Point is The End of The Arm.
- Capacities Marked with an Asterisk (*) are Limited by Hydraulic Capacities.
- Lifting Capacities Shown Do Not Exceed 75% of Minimum Tipping Loads or 87% of Hydraulic Capacities.
- The Least Stable Position is Over the Side.

📏 : Rating Over Front
📏 : Rating Over Side or 360 Degree

OPTION 2

Metric

Boom : 6,500mm(21'4") Arm : 3,200mm(10'6") Bucket : Without Bucket Shoe : 600mm(24") Narrow Track : 3,000mm(9'8") Unit : 1,000kg

A(m)	1.5		3.0		4.5		6.0		7.5		9.0		Max. Reach		A(m)	
B(m)	📏	📏	📏	📏	📏	📏	📏	📏	📏	📏	📏	📏	📏	📏	📏	
7.5														* 7.68	6.58	7.71
6.0														* 7.78	6.51	8.59
4.5					11.99	11.99	* 9.58	8.87	* 8.33	6.27	* 7.68	4.63		7.55	4.51	9.14
3.0					15.08	12.46	11.03	8.28	* 9.07	5.98	7.61	4.50		7.08	4.18	9.42
1.5					17.22	11.53	12.28	7.78	* 9.76	5.70	7.46	4.36		6.93	4.05	9.45
0					17.80	11.14	12.95	7.46	9.59	5.50	7.35	4.26		7.08	4.11	9.23
-1.5					14.10	14.10	12.72	11.07	12.91	7.33	9.48	5.40		7.61	4.40	8.76
-3.0	16.79	16.79	21.31	21.31	15.81	11.20	12.07	7.37	* 9.30	5.45				* 8.45	5.06	7.97
-4.5			17.23	17.23	13.14	11.52	* 9.96	7.60						* 8.35	6.51	6.76

Feet

Unit : 1,000ld

A(ft)	5		10		15		20		25		30		Max. Reach		A(ft)	
B(ft)	📏	📏	📏	📏	📏	📏	📏	📏	📏	📏	📏	📏	📏	📏	📏	
25														* 17.04	14.06	25.01
20														* 17.03	13.99	28.04
15					* 25.78	* 25.78	* 20.75	19.13	* 18.15	13.51				16.73	9.98	29.92
10					* 32.42	26.95	* 23.86	17.89	* 19.71	12.89	16.37	9.68		15.62	9.22	30.88
5					* 37.17	24.89	* 26.57	16.79	21.13	12.29	16.05	9.39		15.27	8.93	31.00
0					* 38.57	24.00	* 28.05	16.09	20.64	11.85	15.83	9.19		15.61	9.07	30.30
-5					* 31.86	* 31.86	* 37.46	23.84	* 27.98	15.80	20.43	11.66		16.82	9.73	28.69
-10	* 37.58	* 37.58	* 46.30	* 46.30	* 34.25	24.12	* 26.07	15.89	* 19.94	11.79				* 18.63	11.22	26.03
-15			* 37.09	* 37.09	* 28.22	24.84	* 21.20	16.43						* 18.36	14.59	21.92

- Lifting Capacities are in Compliance with ISO 10567
- Loading Point is The End of The Arm.
- Capacities Marked with an Asterisk (*) are Limited by Hydraulic Capacities.
- Lifting Capacities Shown Do Not Exceed 75% of Minimum Tipping Loads or 87% of Hydraulic Capacities.
- The Least Stable Position is Over the Side.

📏 : Rating Over Front
📏 : Rating Over Side or 360 Degree

LIFTING CAPACITY

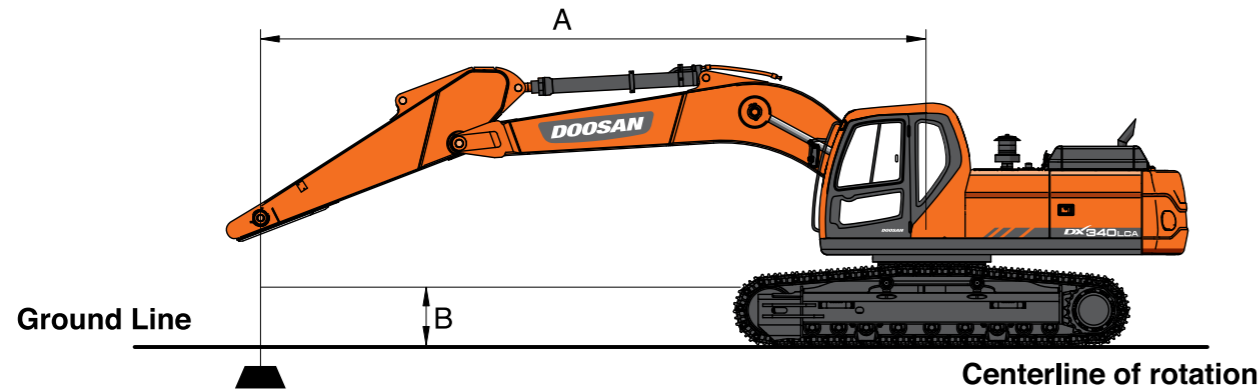

OPTION 3

Metric

Boom : 6,500mm(21'4") Arm : 2,600mm(8'6") Bucket : Without Bucket Shoe : 600mm(24") Standard Track : 3,200mm(10'6") Unit : 1,000kg

A(m)	1.5		3.0		4.5		6.0		Max. Reach		A(m)
B(m)	☺	☹	☺	☹	☺	☹	☺	☹	☺	☹	A(m)
7.5									* 8.56	8.13	6.98
6.0					* 9.20	* 9.20	* 8.46	7.15	* 8.38	6.47	7.95
4.5			13.37	13.37	10.36	9.77	* 8.90	6.95	* 8.38	5.64	8.53
3.0					11.71	9.21	* 9.55	6.68	7.85	5.21	8.83
1.5					12.75	8.76	9.84	6.43	7.68	5.07	8.87
0			17.72	12.89	13.14	8.51	9.67	6.27	7.90	5.18	8.64
-1.5			16.74	12.93	12.79	8.44	9.62	6.23	8.61	5.62	8.12
-3.0	18.82	18.82	14.88	13.14	11.54	8.56			* 9.05	6.63	7.26
-4.5	14.37	14.37	11.56	11.56					* 8.64	* 8.64	5.91

Feet

Unit : 1,000ld

A(ft)	10		15		20		25		Max. Reach		A(ft)
B(ft)	☺	☹	☺	☹	☺	☹	☺	☹	☺	☹	A(ft)
25									* 18.93	18.37	22.58
20					* 20.01	* 20.01	* 18.56	15.36	* 18.48	14.45	25.90
15			* 28.69	* 28.69	* 22.42	21.08	* 19.39	14.97	* 18.46	12.49	27.93
10					* 25.31	19.88	* 20.73	14.40	17.34	11.51	28.96
5					* 27.59	18.90	21.20	13.87	16.94	11.17	29.09
0			* 38.48	27.73	* 28.48	18.34	20.82	13.53	17.41	11.42	28.34
-5	* 32.52	* 32.52	* 36.37	27.80	* 27.72	18.21	20.74	13.45	19.02	12.42	26.62
-10	* 40.99	* 40.99	* 32.24	28.26	* 24.89	18.46			* 19.94	14.72	23.72
-15	* 30.87	* 30.87	* 24.70	* 24.70					* 18.93	* 18.93	19.10

- Lifting Capacities are in Compliance with ISO 10567
- Loading Point is The End of The Arm.
- Capacities Marked with an Asterisk (*) are Limited by Hydraulic Capacities.
- Lifting Capacities Shown Do Not Exceed 75% of Minimum Tipping Loads or 87% of Hydraulic Capacities.
- The Least Stable Position is Over the Side.

☺ : Rating Over Front
☹ : Rating Over Side or 360 Degree

OPTION 4

Metric

Boom : 6,500mm(21'4") Arm : 2,600mm(8'6") Bucket : Without Bucket Shoe : 700mm(28") Standard Track : 3,200mm(10'6") Unit : 1,000kg

A(m)	3.0		4.5		6.0		7.5		Max. Reach		A(m)
B(m)	☺	☹	☺	☹	☺	☹	☺	☹	☺	☹	A(m)
7.5									* 8.56	8.19	6.98
6.0					* 9.20	* 9.20	* 8.46	7.2	* 8.38	6.52	7.95
4.5			13.37	13.37	10.36	9.84	* 8.90	7.0	* 8.38	5.68	8.53
3.0					11.71	9.27	* 9.55	6.73	7.92	5.25	8.83
1.5					12.75	8.82	9.92	6.48	7.75	5.11	8.87
0			17.72	12.98	13.14	8.57	9.75	6.32	7.96	5.22	8.64
-1.5			16.74	13.03	12.79	8.51	9.70	6.28	8.68	5.67	8.12
-3.0	18.82	18.82	14.88	13.23	11.54	8.62			* 9.05	6.69	7.26
-4.5	14.37	14.37	11.56	11.56					* 8.64	* 8.64	5.91

Feet

Unit : 1,000ld

A(ft)	10		15		20		25		Max. Reach		A(ft)
B(ft)	☺	☹	☺	☹	☺	☹	☺	☹	☺	☹	A(ft)
25									* 18.93	18.49	22.58
20					* 20.01	* 20.01	* 18.56	15.47	* 18.48	14.55	25.90
15			* 28.69	* 28.69	* 22.42	21.23	* 19.39	15.07	* 18.46	12.59	27.93
10					* 25.31	20.02	* 20.73	14.50	17.48	11.60	28.96
5					* 27.59	19.04	21.37	13.98	17.08	11.26	29.09
0			* 38.48	27.94	* 28.48	18.49	21.0	13.63	17.56	11.52	28.34
-5	* 32.52	* 32.52	* 36.37	28.02	* 27.72	18.35	20.92	13.56	19.18	12.52	26.62
-10	* 40.99	* 40.99	* 32.24	28.47	* 24.89	18.61			* 19.94	14.84	23.72
-15	* 30.87	* 30.87	* 24.70	* 24.70					* 18.93	* 18.93	19.10

- Lifting Capacities are in Compliance with ISO 10567
- Loading Point is The End of The Arm.
- Capacities Marked with an Asterisk (*) are Limited by Hydraulic Capacities.
- Lifting Capacities Shown Do Not Exceed 75% of Minimum Tipping Loads or 87% of Hydraulic Capacities.
- The Least Stable Position is Over the Side.

☺ : Rating Over Front
☹ : Rating Over Side or 360 Degree

OPTION 5

Metric

Boom : 6,500mm(21'4") Arm : 2,600mm(8'6") Bucket : Without Bucket Shoe : 600mm(24") Narrow Track : 3,000mm(9'8") Unit : 1,000kg

A(m)	3.0		4.5		6.0		7.5		Max. Reach		A(m)
B(m)	☺	☹	☺	☹	☺	☹	☺	☹	☺	☹	A(m)
7.5									* 8.56	7.29	6.98
6.0					* 9.20	9.19	* 8.46	6.41	* 8.38	5.79	7.95
4.5			13.37	13.34	10.36	8.71	* 8.90	6.21	* 8.38	5.03	8.53
3.0					11.71	8.16	* 9.55	5.94	7.82	4.64	8.83
1.5					12.75	7.73	9.81	5.70	7.65	4.50	8.87
0			17.72	11.19	13.14	7.48	9.63	5.54	7.87	4.59	8.64
-1.5			16.74	11.23	12.79	7.42	9.59	5.51	8.58	4.98	8.12
-3.0	18.82	18.82	14.88	11.43	11.54	7.53			* 9.05	5.87	7.26
-4.5	14.37	14.37	11.56	11.56					* 8.64	* 8.06	5.91

Feet

Unit : 1,000ld

A(ft)	10		15		20		25		Max. Reach		A(ft)
B(ft)	☺	☹	☺	☹	☺	☹	☺	☹	☺	☹	A(ft)
25									* 18.93	16.48	22.58
20					* 20.01	19.81	* 18.56	13.76	* 18.48	12.93	25.90
15			* 28.69	* 28.69	* 22.42	18.81	* 19.39	13.37	* 18.46	11.15	27.93
10					* 25.31	17.64	* 20.73	12.82	17.28	10.24	28.96
5					* 27.59	16.68	21.12	12.30	16.87	9.91	29.09
0			* 38.48	24.10	28.48	16.15	20.74	11.97	17.35	10.12	28.34
-5	* 32.52	* 32.52	* 36.37	24.18	* 27.72	16.02	20.66	11.90	18.94	10.99	26.62
-10	* 40.99	* 40.99	* 32.24	24.62	* 24.89	16.26			* 19.94	13.03	23.72
-15	* 30.87	* 30.87	* 24.70	* 24.70					* 18.93	18.18	19.10

- Lifting Capacities are in Compliance with ISO 10567
- Loading Point is The End of The Arm.
- Capacities Marked with an Asterisk (*) are Limited by Hydraulic Capacities.
- Lifting Capacities Shown Do Not Exceed 75% of Minimum Tipping Loads or 87% of Hydraulic Capacities.
- The Least Stable Position is Over the Side.

☺ : Rating Over Front
☹ : Rating Over Side or 360 Degree

LIFTING CAPACITY

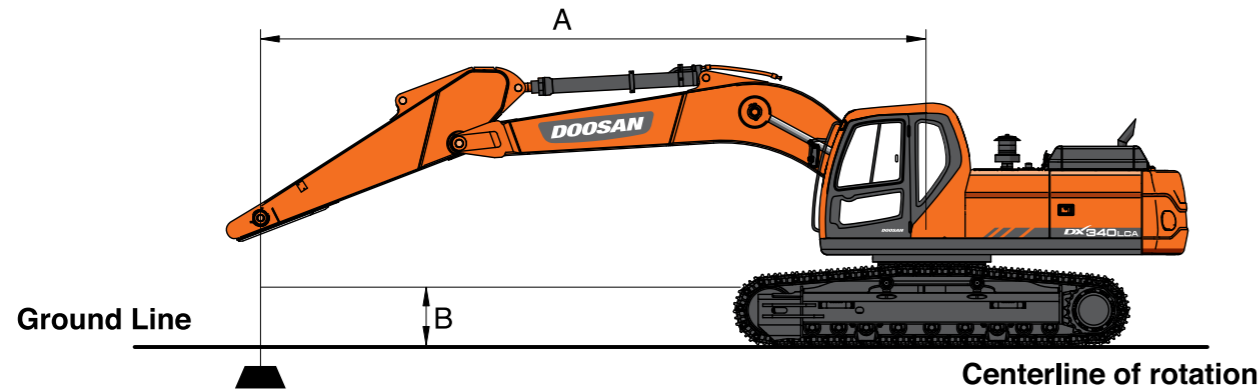

OPTION 7

Metric

Boom : 6,200mm(20'4") Arm : 2,600mm(8'6") Bucket : Without Bucket Shoe : 700mm(28") Standard Track : 3,200mm(10'6") Unit : 1,000kg

A(m)	3.0		4.5		6.0		7.5		Max. Reach		A(m)
7.5					* 8.96	* 8.96			* 8.98	* 8.98	6.58
6.0					* 9.33	* 9.33	* 8.78	7.22	* 8.78	7.05	7.61
4.5			13.09	13.09	10.41	9.98	* 9.11	7.07	* 8.78	6.09	8.22
3.0			16.08	14.32	11.75	9.45	* 9.71	6.83	8.43	5.61	8.53
1.5			17.89	13.51	12.85	9.01	10.04	6.60	8.24	5.46	8.56
0			18.06	13.24	13.31	8.75	9.87	6.44	8.50	5.60	8.32
-1.5	17.81	17.81	17.13	13.24	12.96	8.68	9.84	6.41	9.33	6.11	7.79
-3.0	19.66	19.66	15.13	13.44	11.54	8.79			* 9.58	7.31	6.89
-4.5	14.42	14.42	11.28	11.28					* 9.07	* 9.07	5.44

Feet

Unit : 1,000ld

A(ft)	10		15		20		25		Max. Reach		A(ft)
25					* 19.80	* 19.80			* 19.88	* 19.88	21.27
20					* 20.34	* 20.34			* 19.36	15.74	24.78
15			* 28.61	* 28.61	* 22.57	21.52	* 19.88	15.22	* 19.35	13.51	26.89
10			* 34.59	30.92	* 25.44	20.40	* 21.12	14.72	18.61	12.40	27.96
5			* 38.66	29.13	* 27.82	19.44	21.63	14.22	18.18	12.03	28.10
0			* 39.18	28.49	* 28.84	18.86	21.27	13.90	18.74	12.34	27.31
-5	* 40.41	* 40.41	* 37.19	28.49	* 28.08	18.71	21.23	13.86	20.62	13.50	25.53
-10	* 42.73	* 42.73	* 32.74	28.93	* 24.84	18.98			* 21.11	16.26	22.49
-15	* 30.82	* 30.82	* 23.94	* 23.94					* 19.85	* 19.85	17.53

1. Lifting Capacities are in Compliance with ISO 10567

2. Loading Point is The End of The Arm.

3. Capacities Marked with an Asterisk (*) are Limited by Hydraulic Capacities.

4. Lifting Capacities Shown Do Not Exceed 75% of Minimum Tipping Loads or 87% of Hydraulic Capacities.

5. The Least Stable Position is Over the Side.

: Rating Over Front

: Rating Over Side or 360 Degree

OPTION 6

Metric

Boom : 6,200mm(20'4") Arm : 2,600mm(8'6") Bucket : Without Bucket Shoe : 600mm(24") Standard Track : 3,200mm(10'6") Unit : 1,000kg

A(m)	3.0		4.5		6.0		7.5		Max. Reach		A(m)
7.5					* 8.96	* 8.96			* 8.98	8.98	6.58
6.0					* 9.33	* 9.33	* 8.78	7.17	* 8.78	7.0	7.61
4.5			13.09	13.09	10.41	9.91	* 9.11	7.02	* 8.78	6.05	8.22
3.0			16.08	14.22	11.75	9.39	* 9.71	6.78	8.36	5.57	8.53
1.5			17.89	13.41	12.85	8.94	9.96	6.55	8.94	5.42	8.56
0			18.06	13.14	13.31	8.68	9.79	6.39	8.43	5.55	8.32
-1.5	17.81	17.81	17.13	13.14	12.96	8.61	9.76	6.36	9.26	6.06	7.79
-3.0	19.66	19.66	15.13	13.34	11.54	8.73			* 9.58	7.26	6.89
-4.5	14.42	14.42	11.28	11.28					* 9.07	* 9.07	5.44

Feet

Unit : 1,000ld

A(ft)	10		15		20		25		Max. Reach		A(ft)
25					* 19.80	* 19.80			* 19.88	* 19.88	21.27
20					* 20.34	* 20.34			* 19.36	15.63	24.78
15			* 28.16	* 28.16	* 22.57	21.38	* 19.88	15.12	* 19.35	13.41	26.89
10			* 34.59	30.71	* 25.44	20.26	* 21.12	14.61	18.46	12.30	27.96
5			* 38.66	28.91	* 27.82	19.29	21.46	14.12	18.03	11.94	28.10
0			* 39.18	28.27	* 28.84	18.72	21.10	13.79	18.59	12.24	27.31
-5	* 40.41	* 40.41	* 37.19	28.27	* 28.08	18.57	21.05	13.75	20.46	13.39	25.53
-10	* 42.73	* 42.73	* 32.74	28.72	* 24.84	18.84			* 21.11	16.14	22.49
-15	* 30.82	* 30.82	* 23.94	* 23.94					* 19.85	* 19.85	17.53

1. Lifting Capacities are in Compliance with ISO 10567

2. Loading Point is The End of The Arm.

3. Capacities Marked with an Asterisk (*) are Limited by Hydraulic Capacities.

4. Lifting Capacities Shown Do Not Exceed 75% of Minimum Tipping Loads or 87% of Hydraulic Capacities.

5. The Least Stable Position is Over the Side.

: Rating Over Front

: Rating Over Side or 360 Degree

OPTION 8

Metric

Boom : 6,200mm(20'4") Arm : 2,600mm(8'6") Bucket : Without Bucket Shoe : 600mm(24") Narrow Track : 3,000mm(9'8") Unit : 1,000kg

A(m)	3.0		4.5		6.0		7.5		Max. Reach		A(m)
7.5					* 8.96	* 8.96			* 8.98	8.06	* 6.58
6.0					* 9.33	9.27	* 8.78	6.43	* 8.78	6.27	* 7.61
4.5			13.09	13.09	10.41	8.85	* 9.11	6.28	* 8.78	5.40	* 8.22
3.0			16.08	12.47	11.75	8.34	* 9.71	6.04	8.33	4.96	* 8.53
1.5			17.89	11.70	12.85	7.91	9.93	5.82	8.15	4.81	* 8.56
0			18.06	11.44	13.31	7.66	9.76	5.67	8.40	4.93	* 8.32
-1.5	17.81	17.81	17.13	11.44	12.96	7.59	9.73	5.64	9.22	5.38	* 7.79
-3.0	19.66	19.66	15.13	11.63	11.54	7.70			* 9.58	6.43	* 6.89
-4.5	14.42	14.42	11.28	11.28					* 9.07	* 9.07	* 5.44

Feet

Unit : 1,000ld

A(ft)	10		15		20		25		Max. Reach		A(ft)
25					* 19.80	* 19.80			* 19.88	18.24	21.27
20					* 20.34	19.98			* 19.36	14.01	24.78
15			* 28.16	* 28.16	* 22.57	19.10	* 19.88	13.52	* 19.35	11.98	26.89
10			* 34.59	26.96	* 25.44	18.01	* 21.12	13.03	18.39	10.96	27.96
5			* 38.66	25.25	* 27.82	17.07	21.38	12.55	17.96	10.61	28.10
0			* 39.18	24.64	* 28.84	16.52	21.02	12.23	18.52	10.86	27.31
-5	* 40.41	* 40.41	* 37.19	24.63	* 28.08	16.37	20.97	12.19	20.38	11.88	25.53
-10	* 42.73	* 42.73	* 32.74	25.06	* 24.84	16.63			* 21.11	14.30	22.49
-15	* 30.82	* 30.82	* 23.94	* 23.94					* 19.85	* 19.85	17.53

1. Lifting Capacities are in Compliance with ISO 10567

2. Loading Point is The End of The Arm.

3. Capacities Marked with an Asterisk (*) are Limited by Hydraulic Capacities.

4. Lifting Capacities Shown Do Not Exceed 75% of Minimum Tipping Loads or 87% of Hydraulic Capacities.

5. The Least Stable Position is Over the Side.

: Rating Over Front

: Rating Over Side or 360 Degree

STANDARD & OPTION

STANDARD EQUIPMENT

Boom & Arm

- 6.5m Boom (Heavy duty)
- 2.6 Arm (Heavy duty)

Hydraulic system

- Boom and arm flow regeneration
- Boom and arm holding valves
- Swing anti-rebound valves
- Spare ports (Control valve)
- One-touch power boost

Cabin & Interior

- Viscous cab mounts
- All weather sound suppressed type cab
- Air conditioner & Heater
- Adjustable suspension seat with head rest and adjustable arm rest
- Pull-up type front window and removable lower front window
- Room light
- Intermittent windshield wiper
- Cigarette lighter and ashtray
- Cup holder
- Hot & Cool box
- LCD color monitor panel
- E/G RPM control dial
- AM/FM radio + MP3 (USB)
- Remote radio ON/OFF switch
- 12V spare powers socket
- Serial communication port for laptop PC interface
- Joystick lever with 3 switches
- Sun visor
- Sun roof

Safety

- Large handrails and step
- Convex metal anti-slip plates
- Seat belt
- Hydraulic safety lock lever
- Safety glass
- Hammer for emergency escape
- Right and left rearview mirrors
- Travel alarm
- Battery protector cover

Others

- Double element air cleaner
- Water separator
- Dry type pre cleaner
- Fuel filter
- Dust screen for radiator/oil cooler
- Engine overheat prevention system
- Engine restart prevention system
- Self-diagnostic system
- Alternator (24V, 50 amps)
- Electric horn
- Halogen working lights (frame mounted 1, boom mounted 2)
- Hydraulic track adjuster
- Track guards
- Greased and sealed track link
- Hydraulic oil tank air breather filter

OPTIONAL EQUIPMENT

Some of optional equipments may be standard in some markets. Some of this optional equipment is not available in some markets. You must check with the local DOOSAN dealer to know about the availability or to release the adaptation following the needs of the applications

Boom & Arm

- 6.2m Boom
- 6.5m Boom
- 3.2m Arm
- 3.2m Arm (Heavy duty)
- 3.95m Arm

Safety

- Boom and arm hose rupture protection valve
- Overload warning device
- Cabin Top/Front guard (ISO 10262, FOGS standard)
- Travel & swing alarm
- Rotating / Telescopic beacon
- Lock valve
- Rear view camera
- Rear lamp for number plate

Cabin & Interior

- Air suspension seat
- Rain Shield
- High seat Mount
- Breaker pedal
- ROPS/FOGS Cabin
- Cabin front guard (Upper and lower guard)
- Steel roof cover
- Side mirror

Others

- Piping for crusher
- Piping for quick clamp
- Piping option
 - Breaker with flow control valve - Crusher
 - Crusher with tilting - Rotating
 - Clamshell - Quick Clamp
- 700mm/800mm/850mm/900mm shoe
- Lower wiper
- Fuel heater
- 80A alternator
- Fuel filler pump
- Integrated main pump follow
- Working Lights
 - 4-front/2-rear on cabin
 - 2-front on cabin
 - 1 on counterweight
- Counterweight (6.6Ton)
- Noise Kit
- Hydraulic Oil
 - Cold weather (VG32)
 - Normal (VG46)
 - Tropical weather (VG68)
- Narrow track
- Full length track guard
- Breaker filter
- Water Separator with heater
- Oil Washed pre cleaner
- Heavy duty under cover

Doosan is

Since 1896, Doosan, the oldest company in Korea, has evolved with its people. The company grew up rapidly for last 10 years with reputation. For human-oriented vision, Doosan has been building constructions, energy, machines, infra structures globally. As a global leader of infra structure, Doosan continues its vision to make human-oriented future.

First in Korea, Doosan self-developed excavators in 1985 and continued building versatile construction machines including excavators, wheel loaders, articulated dump trucks to execute its human-oriented philosophy. Doosan became a global leader of heavy construction machine industry by achieving global sales line, producing line, and distribution line. Along with large production bases in Korea, China, USA, Belgium, Czech, Brazil, Doosan has 1400 dealer networks and Doosan is providing reliable products and trusted solutions for your stable business at no risk.

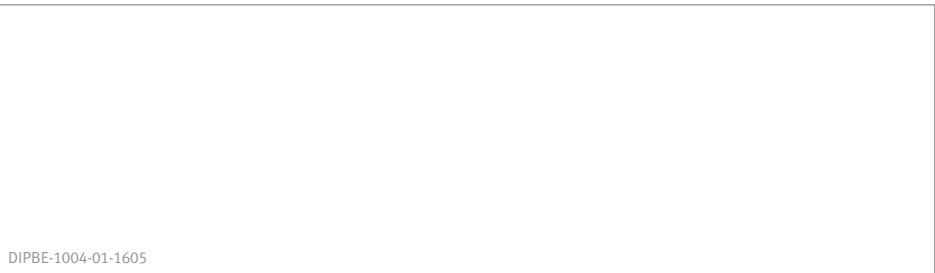

DIPBE-1004-01-1605



Doosan Infracore Korea Office (HQ)
27F, Doosan Tower, 275, Jangchungdan-ro,
Jung-gu, Seoul, Korea(04563)
Tel : 82 2 3398 8114

www.doosaninfracore.com/ce/